

October 1, 2025

United States Department of Energy

Bonneville Power Administration

System Operations

Operating Bulletin NO. 2

Accident Prevention Rule S-6

SWITCHING AND CLEARANCE PROCEDURE



Richard Bustamante

Vice President, Transmission System Operations

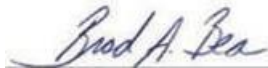

Brad Bea

Chief Safety Officer

United States Department of Energy
Bonneville Power Administration
System Operations
Operating Bulletin NO. 2
Accident Prevention Rule S-6

SWITCHING AND CLEARANCE PROCEDURE

Table of Contents

	Page
I. NERC CERTIFIED SYSTEM OPERATOR	P-1
II. COMMUNICATIONS	P-2
III. TROUBLE REPORTING	P-2
IV. SWITCHING	P-3
IV.1 Authority	P-3
IV.2 Switching Orders	P-4
IV.3 Writing Switching Orders	P-4
IV.4 Executing Switching Orders	P-7
IV.5 Power Circuit Breakers and Isolating Devices	P-9
IV.6 Logging and Reporting	P-11
V. EQUIPMENT OUTAGES	P-12
VI. CLEARANCES	P-12
VI.1 Work and Test Clearances	P-12
VI.2 Equipment and Circuits Included in a Clearance	P-13
VI.3 When Clearances are Required	P-14
VI.4 When Clearances are not Required	P-15
VI.5 Issuing and Receiving Clearances	P-15
VI.6 Provisions of a Clearance	P-19

VI.7	High Voltage Backfeed from Low Voltage Sources Associated with Clearances.....	P-20
VI.8	Ground Switches Associated with Clearances.....	P-20
VI.9	Clearance Responsibilities.....	P-21
VI.10	Releasing Clearances.....	P-25
VI.11	Logging Clearances.....	P-29
VII.	HOLD ORDERS	P-29
VII.1	When Hold Orders are Required.....	P-29
VII.2	Application for Hold Orders.....	P-30
VII.3	Issuing and Receiving Hold Orders.....	P-31
VII.4	Provisions of a Hold Order.....	P-33
VII.5	Hold Order Responsibilities.....	P-34
VII.6	Releasing Hold Orders.....	P-36
VII.7	Logging Hold Orders.....	P-37
VIII.	WORK PERMITS	P-38
VIII.1	When Work Permits are Required.....	P-38
VIII.2	Application for Work Permits.....	P-38
VIII.3	Issuing and Receiving Work Permits.....	P-38
VIII.4	Work Permit Responsibilities.....	P-39
VIII.5	Releasing Work Permits.....	P-40
VIII.6	Logging Work Permits.....	P-40
IX.	LOW VOLTAGE CIRCUITS, EQUIPMENT AND ENERGY STORAGE SYSTEMS	P-41
X.	TAGGING	P-42
X.1	Types of Tags.....	P-42
X.2	Tagging for Clearances.....	P-44
X.3	Tagging for System Dispatcher or Substation Operator.....	P-52
X.4	Releasing System Dispatcher or Substation Operator Tags.....	P-53

X.5	Tagging for Abnormal, Unusual, Unsafe or Hazardous Conditions	P-53
X.6	Tagging for Hold Orders	P-55
X.7	Isolating Series Capacitors for Reduced MAD for Hold Orders ...	P-58
X.8	Tagging for Work Permits	P-59
X.9	Tagging for De-Energized Low Voltage Circuits	P-62
X.10	Electrical Test Markers	P-63
XI.	COLOR ADDENDUM	A-1
	AT THE JOB SITE INTERPRETATIONS	C-1
	GLOSSARY OF SPECIAL TERMS AND PHRASES	D-1

United States Department of Energy
Bonneville Power Administration
System Operations
Operating Bulletin NO. 2
Accident Prevention Rule S-6

SWITCHING AND CLEARANCE PROCEDURE

This document contains the rules, procedures, and suggested examples to be followed for communicating, trouble reporting, and switching; issuance of Clearances, Hold Orders and Work Permits; work on low voltage circuits; and tagging on the BPA Power System.

Rules appear in bold font. Procedures and suggested examples appear in standard font. Substation Operators may be referred to as Operators. Power System Dispatchers may be referred to as Dispatchers.

The BPA-WS-3 sequence of Work Standards supplements the Switching and Clearance Procedure and is integral to the correct application and understanding of requirements contained within the Switching and Clearance Procedure.

I. NERC CERTIFIED SYSTEM OPERATOR

Dispatchers are North American Electric Reliability Corporation (NERC) certified System Operators who possess the authority under their NERC certification and DSO 136, Dispatcher's System Authority, to exercise their judgment in the execution of processes and procedures provided in the Switching and Clearance Procedure.

II. COMMUNICATIONS

- II.1 **When communicating about Switching, Clearances, Hold Orders, Work Permits, Tagging, and Trouble Reporting, personnel shall identify themselves to each other and be absolutely sure they know with whom they are talking.**
- II.2 **Conversations must be clear, concise, and must be conducted in a business-like manner.**

Conversations may be held through a third party when necessary.
- II.3 **Personnel must exchange information using proper line and equipment terminology so that all parties have a clear understanding of the work to be performed.**
- II.4 **For switching and the issuing and release of Clearances and Hold Orders on transmission lines outside substations, the VHF radio shall be used as the primary means of communication. If the VHF radio is inadequate, an alternate means of communication may be used.**

III. TROUBLE REPORTING

- III.1 **Trouble on power system equipment affecting the operation or protection of the BPA power system shall be immediately reported to the appropriate System Dispatcher.**
- III.2 **Trouble on power system equipment affecting the operation of a substation, but which does not affect operation or protection of the BPA power system, shall be immediately reported to District Substation Operations.**

IV. SWITCHING

IV.1 Authority

A. Permission is required before anyone may switch power system equipment which affects the operation or protection of the power system (Dispatcher) or substation (Substation Operations). This authority may be delegated to a Switchman.

- (1) During cases of trouble on power system equipment which affects the operation or protection of the power system, the Substation Operator or Switchman shall contact the BPA Dispatcher for direction to restore equipment to service. No switching to restore equipment to service during trouble situations shall be done except as directed by the BPA System Dispatcher.
- (2) During cases of trouble on substation equipment which does not affect the operation or protection of the power system, the Substation Operator or Switchman shall do switching as necessary to clear damaged equipment or to restore equipment to normal.
- (3) A Dispatcher may direct the use of Station Clearances or Station Work Permits on equipment under Dispatcher jurisdiction.

Station Clearance and Station Work Permit procedures are provided in BPA Work Standard BPA-WS-3-1, Switching Process.

B. In emergency situations when life or property is endangered, any Switchman may de-energize lines or equipment and perform such switching as necessary according to his or her best judgment. The Dispatcher must be notified and involved as soon as practical.

- C. **A customer's feeder may be de-energized by a Switchman at the request of the customer.**

IV.2 Switching Orders

- A. **A Switching Order is required, unless specifically ordered otherwise by the Dispatcher:**

- (1) **For all switching and/or tagging involving the issuance and release of Clearances.**
- (2) **For all high voltage switching and/or tagging while in a substation switchyard.**

An example of "or tagging" includes checking open and tagging an isolating device or removal of those same tags.

- (3) **Anytime a Dispatcher or Substation Operator requires a Switching Order for equipment under Dispatcher or Substation Operations jurisdiction.**

IV.3 Writing Switching Orders

- A. **All Switching Orders shall be written on a Switching Order Form (BPA F 6510.04).**

closing of more than one disconnect switch may be included in a single step.

- (2) No erasures shall be made on Switching Orders. No lines shall be skipped and no additions or insertions shall be made between lines. If information is written incorrectly and immediately noticed, a line may be drawn through the incorrect portion, initialed, and the correct instruction written immediately following the deleted portion. Otherwise the Switching Order shall be voided and a new one written.**
- (3) The Switching Order Form heading and ending shall be completely filled in.**
- (4) The Dispatcher may require the Switchman to read the Switching Order for approval. Unless clarification or revision is necessary, the Dispatcher is not required to repeat back the order in detail.**
- (5) The Dispatcher may order a single line in the Switching Order lined out and initialed, order a line added at the end of a Switching Order (e.g., ground switch operation), or order the Switching Order voided and a new one written.**
- (6) Once the Switching Order has received approval or permission to execute, no changes or additions shall be made.**

C. Preparing a Switching Order

- (1) A Pre-Switching Inspection shall be performed by the Switchman in charge of the switching prior to contacting the Dispatcher for Switching Order approval. Pre-Switching Inspections may only be waived during emergencies, or as directed by the Dispatcher during trouble situations.**

For Pre-Switching requirements, refer to BPA Work Standard BPA-WS-3-1, Switching Process.

(2) Utilize available resources in preparing the Switching Order.

These include station prints, Station Instructions, BPA Work Standards, other crafts, Dispatcher, other District Operators, Chief Operator, etc.

(3) Relay protection, transfer and selector switches, and stability control schemes (RAS) affected by the switching must be checked prior to writing a Switching Order.

(4) In preparing to write the Switching Order, mentally and/or physically walk through the switching.

For example, review the switching with the mimic bus, with a station one-line diagram or by physically walking through the switching.

(5) Only approved abbreviations as listed in BPA Work Standard BPA-WS-3-1, Switching Process, shall be used.

IV.4 Executing Switching Orders

A. All Switching Orders on the BPA power system shall be executed by a Substation Operator. Switching Orders may be executed by a Switchman approved by the Dispatcher during trouble or emergency situations.

- (1) The Dispatcher has authority to issue emergency orders to be carried out at once even though a previous Switching Order is in progress.
- (2) If it becomes necessary to write and execute a second Switching Order before a previous Switching Order is completed, the Dispatcher and Switchman must proceed with extreme care to avoid conflicts and errors.

- (3) If it becomes necessary for a Switchman to perform a Switching Order written by another Switchman, the Switchman who is to perform the switching must review the Switching Order before starting the switching. That Switchman will signify that a review has been made and that he or she understands and agrees with the switching procedure by placing their initials after the last line of the Switching Order.
- (4) If the Switchman performing the switching is in need of information or advice, the Dispatcher should be consulted.

B. Only approved abbreviations as listed in BPA Work Standard BPA-WS-3-1, Switching Process, shall be used during communications. Verbal short cuts and verbal abbreviating shall not be used.

C. Each power circuit breaker to be operated or checked shall be identified by its designated System Operations number and name.

PCB(s) shall be checked open before operating isolating devices.

Immediately prior to operating a PCB, the Switchman shall check the Dispatcher number against the Switching Order and make sure they agree. The Switchman shall also check the panel meters to ensure the readings before and after operation are what was anticipated.

D. Each isolating device to be operated or checked shall be identified by its designated System Operations number, name, and/or location, e.g., B-1212 line side disconnect, A-828 main bus sectionalizing disconnect. Each low voltage device shall be identified by its designated substation number, name, and/or location.

Immediately prior to operating any isolating device, the Switchman shall check the Dispatcher number

and/or name of the isolating device to be operated against the Switching Order and make sure they agree. Where possible, the Switchman shall also check that the isolating device is in the proper position before operating it.

- E. The Switchman shall perform the switching steps in the same sequence as written in the Switching Order.**
- F. The Switchman shall carry the Switching Order while performing the switching, and shall check off each step as it is completed.**
- G. If, while executing a Switching Order, an isolating device is found to be in a position other than expected or anticipated or the Switchman has reason to believe any further switching would be improper, no further switching shall be done until the System Dispatcher or Substation Operator is consulted.**
- H. The System Dispatcher or Substation Operator shall promptly be informed whenever a switching operation or Switching Order is completed.**
- I. Additional switching practices are addressed in BPA Work Standard BPA-WS-3-1, Switching Process.**

IV.5 Power Circuit Breakers and Isolating Devices

A. Power Circuit Breakers

The Switchman shall ensure operational readiness prior to switching.

Operational inspections prior to and after the operation of power circuit breakers are described in BPA Work Standard BPA-WS-3-2, Equipment Operation.

An inspection is performed prior to switching any time the breaker has operated due to relay

action, or when the Pre-Switching Inspection indicates a need.

B. Isolating Devices

The Switchman shall ensure operational readiness prior to switching.

An inspection of isolating devices is performed just prior to operation.

Operational requirements and switching safety prior to and during operation is described in BPA Work Standard BPA-WS-3-1, Switching Process.

Operating inspections, characteristics, capabilities, switching processes, and power flow study requirements for isolating devices with or without attachments are addressed in BPA Work Standard BPA-WS-3-2, Equipment Operation (including the Switching Device Capabilities Table).

C. Isolating Devices Used as a Limit of a Clearance

- (1) After a Clearance is issued no material, device or equipment of any kind shall be inserted into the air gap provided by an isolating device used as a Clearance limit.**
- (2) If a fused disconnect has been opened and/or removed, tagged and a Clearance issued, the fuse shall not be placed back into the fuse holder until the Clearance has been released. Fuses may only be placed back into the fuse holder and/or closed when executing an approved Switching Order.**
- (3) Work may be performed on de-energized bus links, jumpers, or sectionalizing jumper couplings that are limits of a Clearance provided all the following conditions are met:**
 - (a) They are either removed or open and adequately restrained at all times as determined by the Clearance Holder.**

- (b) **The Minimum Approach Distance (Rule M-1) is not violated.**
- (c) **Holders of all Clearances using that limit and Electrical Worker Permit holders and other Electrical Workers involved in the work agree the work can be accomplished safely. All Clearance Holders will be kept informed of the status of the work on the device.**
- (d) **The isolating devices shall remain tagged with Do Not Operate tags at all times.**

IV.6 Logging and Reporting

- A. All switching operations shall be recorded in the Substation Operating Log with the following specific information in the exact order executed.**

The Log entry shall include:

- (1) The date and time of starting the switching
- (2) The Switching Order number
- (3) The name of the Dispatcher or Substation Operator approving or granting permission to execute the Switching Order
- (4) The Switchman's name
- (5) The purpose of the switching
- (6) The times of all major operations of the Switching Order
- (7) The time the Switching Order was completed
- (8) The time the Switching Order was reported, the name of the person reporting, and the Dispatcher or Operator to whom it was reported

- B. The operation of all ground switches shall be recorded in red in the Substation Operating Log.**

- C. Only approved abbreviations shall be used when writing in the Substation Operating Log. Refer to BPA Work Standard BPA-WS-3-1, Switching Process.

V. EQUIPMENT OUTAGES

Applications for Clearances, Hold Orders and Work Permits on the BPA high voltage system shall be submitted in accordance with the requirements of BPA's Outage Planning and Coordination Policy. The Outage Planning and Coordination Policy can be accessed from the BPA System Operations share point site at:

<https://txportal.bud.bpa.gov/orgs/TO/TOR/BPAOutageOffice/OutageCoordination/SOLViolation/Forms/AllItems.aspx>

VI. CLEARANCES

VI.1 Work and Test Clearances

- A. There are two types of Clearances, and the activity determines the type of Clearance needed.
 - (1) A Work Clearance provides protection when work is to be performed on de-energized high voltage lines or equipment. Electrical tests may be performed on equipment included in a Work Clearance if:
 - (a) The high voltage equipment is contained in a substation.
 - (b) The equipment is under the physical control of the Clearance Holder.
 - (c) AND the equipment is separated from the rest of the de-energized high voltage equipment in the Clearance by means sufficient to positively prevent the test voltages and/or currents from entering the remainder of the equipment protected by the Clearance.

(2) A Test Clearance provides protection when electrical tests are to be performed on high voltage equipment and the conditions required for application of electrical tests under a Work Clearance in A (1), (a), (b), or (c) cannot be met.

B. More than one Work Clearance may be issued on the same line or equipment to multiple crews.

C. Under the following circumstances more than one Work Clearance may be issued to members of the same crew for work on the same equipment:

(1) If the expected duration of the work is one month or more, a second Clearance Holder may be requested at the time the outage request is made.

(2) Transformer dry-outs (or similar type work) where work occurs around the clock or during significantly extended workdays where one Clearance Holder must relieve another Clearance Holder because of the on-going nature of the work. A second and, if necessary, third Clearance Holder could be requested at the time the outage request is made for this type of work.

D. When a Test Clearance is issued on a line or equipment, no other Test Clearance or Work Clearance may be issued on the same line or equipment.

VI.2 Equipment and Circuits Included in a Clearance

When a Clearance is issued, it will include all of the high voltage circuits and equipment within the limits of the Clearance and jurisdiction over low voltage circuits within the equipment, which can be isolated at the high voltage equipment.

If the holder of the Clearance will need jurisdiction over more of the low voltage circuitry than is normally included, these additional circuits should be requested to be tagged for the Clearance Holder.

VI.3 When Clearances are Required

A. A Work Clearance or a Test Clearance is required:

- (1) Before workers contact or come within the applicable Minimum Approach Distance of any high voltage line or equipment that could become energized by the closing of a high voltage isolating device.**

High voltage is defined as any voltage above 600v. See APM Rule L-2, Low Voltage Circuit, Work On.

- (2) Before any high voltage line or equipment may be installed or removed when energization of the line or equipment could result by the closing of a high voltage isolating device.**

A Clearance or Hold Order, as appropriate, is required during the time isolating devices are being put in place to make connection to the power system.

- (3) Before installing or removing any high voltage conductor which crosses over or under normally energized high voltage lines or equipment unless the work can be accomplished under the protection of a Hold Order.**

B. A Test Clearance is required before electrical test voltages and/or currents may be applied to any high voltage equipment that could become energized by the closing of a high voltage isolating device and the conditions required for

application of electrical tests under a Work Clearance cannot be met.

VI.4 When Clearances are not Required

A. New Construction

During the construction of new facilities, a Clearance is not required if power system equipment is not in place to provide a connection to the power system by the closing of an isolating device.

B. Return to Construction Status

During reconductoring of existing lines, removal and/or replacement of facilities, or for other similar type work, a Clearance is not required providing that a Request for Return to Construction Status (BPA Form 6500.13e) requesting the work to be accomplished without a Clearance has been submitted to and approved in writing by the Manager of the Dispatching Office having jurisdiction over the equipment. Under the protection of a Clearance, the facilities will be separated from all possible sources of energization by the physical removal of the predefined circuit parts such as risers, wire spans, bus work, or other conductor, which completely separates the equipment from the power system.

BPA Work Standard BPA-WS-3-3, Work on Equipment Separated from the Power System, is an extension of OB #2, Section VI.4, When Clearances are not Required.

VI.5 Issuing and Receiving Clearances

A. All Clearances on the BPA power system shall be issued by a System Dispatcher or Substation Operator. The System Dispatcher or Substation Operator may delegate the authority to issue Clearances to a Switchman.

The Dispatcher or Operator having jurisdiction over the facilities that are cleared is responsible for issuance of the Clearance.

- (1) A Dispatcher's Clearance is issued by or with the permission of the Dispatcher who has jurisdiction over the facilities that are cleared.
- (2) A Station Clearance is issued by an Operator who has jurisdiction over the facilities that are cleared.

- B. At the time a Clearance is issued on a transmission line or on a transmission line section, the Clearance Holder shall communicate the working location in relation to the Clearance limits to the Dispatcher or Substation Operator issuing the Clearance.**
- C. When more than one Clearance is issued or is to be issued on a transmission line or associated terminal equipment, each Clearance Holder shall be given the names of the other Clearance Holders and advised of the type of work that each Clearance Holder will be performing. All Clearance Holders shall be informed of this at the time of receiving their Clearance. Existing Clearance Holders shall be advised of additional Clearance requests prior to the issuance of any new Clearance(s).**
- D. In emergencies when no communications are available, Switchmen may do necessary switching and tagging and issue Clearances to themselves.**
- E. Clearances will be issued to individuals in the Permit Directory with a Clearance Certification, and to Dispatchers and qualified personnel of foreign utilities or customers.**

When issuing a Clearance, the Dispatcher or Operator shall state clearly to the person receiving the Clearance:

- (1) The name of the person receiving the Clearance.**

- (2) **The exact name of the line or equipment that is cleared and tagged.**
- (3) **The type of Clearance being issued.**
- (4) **The Clearance number.**
- (5) **The position of available ground switches.**

Example: "John Doe, the Central-East Columbia No. 3 230 kV line is cleared and tagged for you on Work Clearance No. M-4567-W and ground switches at Central and East Columbia are open."

When receiving a Clearance, the Clearance Holder shall repeat back to the Dispatcher or Operator:

- (1) **The name of the person receiving the Clearance.**
- (2) **The exact name of the line or equipment that is cleared and tagged.**
- (3) **The type of Clearance being received.**
- (4) **The Clearance number.**
- (5) **The position of available ground switches.**

Example: "This is John Doe and I understand that the Central-East Columbia No. 3 230 kV line is cleared and tagged for me on Work Clearance No. M-4567-W and ground switches at Central and East Columbia are open."

- F. When a Clearance is received on equipment in a substation, it shall be the Clearance Holder's responsibility to go with the Switchman to:**
- (1) **Point out the specific limits of the Clearance.**
 - (2) **Point out which facilities are included in the Clearance.**

- (3) Point out specific hazards in the work area presented by energized circuits and equipment.**

It shall be the Switchman's responsibility to assure that the above information the Clearance Holder gives is correct.

If the Switchman is not present when the Clearance is issued, the Clearance Holder will assure that their understanding of the above information is correct by touring the Clearance site and checking the tagged isolating devices before any work associated with the Clearance begins.

Other persons present who will work under the Clearance should, where practical, be included in the tours as an aid to fulfilling the Clearance Holder's responsibilities described in VI.9, Clearance Responsibilities.

- G. When crews work on lines or equipment under foreign utility jurisdiction, they will receive Clearances in accordance with the foreign utility's rules and procedures.**
- H. A Clearance issued to an individual by a foreign utility on their line or equipment is issued according to that utility's rules and procedures. This process is accomplished by either of the following:**
 - (1) The BPA Dispatcher can receive the Clearance from the foreign utility and in turn issue a Clearance to the individual, or**
 - (2) The Clearance can be issued directly to the individual by the foreign utility.**

When crews require a Clearance on lines or equipment under a foreign utility's jurisdiction for proximity work on a BPA project, a BPA Dispatcher will issue the Clearance,

Or

In those cases where the foreign utility's determination is to issue directly to an individual, the recipient of the Clearance from the foreign utility shall promptly inform the BPA Dispatcher of the following upon the receipt of the Clearance and before beginning work requiring the protection of a Clearance:

- (1) Name of foreign utility and the name of the person who issued it**
- (2) Time received**
- (3) Foreign utility and foreign utility's circuit identification**
- (4) Work location with respect to BPA transmission line**
- (5) Date, time, and duration of Clearance on the foreign utility's line or equipment**

(Refer to BPA Work Standard BPA-WS-3-5, Clearances and Hold Orders from Foreign Utilities for an example and discussion of each process.)

VI.6 Provisions of a Clearance

With the issuance of a Clearance, the Dispatcher or Substation Operator gives assurance that:

- A. The lines or equipment are separated from the power system with isolating devices.**
- B. All isolating devices are opened, rendered inoperable (if design permits) and tagged.**
- C. None of the tags will be ordered removed and none of the isolating devices will be ordered closed until the Clearance has been released.**

VI.7 High Voltage Backfeed from Low Voltage Sources Associated with Clearances

For the purpose of controlling energization of the high voltage equipment included within the Clearance from potential backfeed through low voltage sources, such as an alternate station service, an engine generator, or as otherwise determined by the Substation Operator, the secondary circuit low voltage isolating device(s) shall be opened and tagged with a Do Not Operate tag for the Clearance Holder.

VI.8 Ground Switches Associated with Clearances

- A. Ground switches associated with Clearances shall remain open unless otherwise agreed among all Clearance applicants on that facility and the Dispatcher or Substation Operator.**
- B. Ground switches shall only be used for personal protection in lieu of portable protective grounds as provided in the APM grounding rules G-1 and G-7.**
- C. The recipient of the Clearance will be informed of ground switch position at the time the Clearance is issued.**
- D. The position of any ground switch associated with a transmission line with multiple Clearance Holders will not be changed until each Clearance Holder on that line has been notified by the Dispatcher and given the opportunity to get personnel in the clear.**

In the event one crew working on a line with multiple Clearance Holders experiences a step and touch potential problem and requests that a ground switch be opened, portable protective grounds shall not be installed as substitutes for the open ground switch.

- E. Ground switches associated with Test Clearances may be operated by the holder of the Test Clearance without permission of the Dispatcher or Substation Operator.**

VI.9 Clearance Responsibilities

A. Clearance Holder Responsibilities

The following responsibilities apply to any holder of a Clearance. Additional responsibilities for electrical work or Work Clearances taken for non-electrical work only are provided in B and C below.

- (1) Shall know the type and limits of the Clearance, the equipment included, and the position of ground switches and isolating devices within the limits of the Clearance. The Clearance Holder shall also know the Clearance number, the time of issue, and the name of the Dispatcher or Substation Operator who issued the Clearance.**
- (2) Shall verify that the intended working location for the Clearance on transmission lines and line sections is within the limits of the Clearance in accordance with BPA Work Standard BPA-WS-3-8, Clearances on Transmission Lines and Line Sections.**
- (3) Shall know the low voltage isolating devices that are opened and tagged for the Clearance Holder.**

If work is to be performed on the low voltage equipment included within the Clearance limits, appropriate Lockout/Tagout procedures shall be followed.

- (4) The Clearance Holder shall convey the information in (1)-(3) above to all persons working under that Clearance before work begins. In addition, any specific hazards**

associated with the work shall be pointed out.

- (5) At the time of receipt of their Clearance, shall know the name(s) of other Clearance Holders and the type of work they are accomplishing when more than one Clearance is issued on the same transmission line.**

This procedure is to prevent job site changes in step and touch potentials due to an unannounced change in grounding.

- (6) Shall direct the installation and removal of portable protective grounds in accordance with the grounding rules before allowing any workers to come within the applicable Minimum Approach Distance of normally energized electrical parts.**
- (7) Shall direct the establishment of an equipotential zone in accordance with the grounding rules before allowing workers to contact normally energized electrical parts.**
- (8) Shall direct the installation of barriers or guards as necessary to prevent accidental contact with adjacent energized equipment before allowing work to begin in areas where such hazards exist.**
- (9) Shall utilize Safety Watchers as required in the APM safety watching rules, or the Contractor Safety and Health Requirements for Prime and Subcontractors (CSHRPS).**
- (10) Shall remain at the job site while work or testing is being performed on equipment under a Clearance.**

- B. Clearance taken for electrical work, the Clearance Holder:**
- (1) When test voltages and/or currents are to be applied to equipment under a Work Clearance, the Clearance Holder shall:**
 - (a) Separate the equipment to be tested from the rest of the de-energized high voltage equipment in the Clearance by means sufficient to positively prevent the test voltages and/or currents from entering the remainder of the equipment protected by the Clearance.**
 - (b) Attach Electrical Test Markers to the equipment to be tested as close to the points of separation as possible.**
 - (c) Notify the Clearance Holders in the immediate area that electrical tests are to be performed.**
 - (d) Supervise or perform the electrical tests.**
 - (e) Remove the Electrical Test Markers and notify other Clearance Holders in the immediate area when the electrical tests are complete.**
 - (2) Portable protective grounds attached to equipment which will be tested (Work or Test Clearances) may be detached during the time test voltages are being applied. No other work than is necessary for application of the electrical tests may be done on that piece of equipment while the protective grounds are removed.**

- C. Work Clearances taken for non-electrical work only, the Clearance Holder:**
- (1) Shall act as Safety Watcher for the crew or assure themselves that there is an Electrical Worker Permit holder to act as Safety Watcher.**
 - (2) Shall remain at the substation while work on equipment under the Clearance is being done if not acting as the Safety Watcher. The Clearance Holder must tell the crew and the Safety Watcher what they are doing and where they will be located at all times while the work requiring the Clearance is being done. The Clearance Holder may do other work but must be available to the crew and the Safety Watcher. At a minimum the Clearance Holder will meet with the crew and the Safety Watcher every 4 hours while work is in progress to exchange information about the work or other issues.**
- D. The Workers:**
- (1) Shall know the type and limits of the Clearance, the equipment included, and the position of ground switches and isolating devices within the limits of the Clearance. The Workers shall verbally acknowledge to the Clearance Holder, the Clearance number, the time of issue, and the name of the Dispatcher or Substation Operator who issued the Clearance. In addition, they shall understand any specific hazards that may be associated with the work.**
 - (2) Shall know and verify the intended working location for the Clearance on transmission lines and line sections is within the limits of the Clearance before commencing work in accordance with BPA Work Standard**

BPA-WS-3-8, Clearances on Transmission Lines and Line Sections.

- (3) Shall know that all low voltage isolating device ACBs that are limits of the Clearance have been tested open before touching or coming within the applicable Minimum Approach Distance of normally energized electrical parts.**
- (4) Shall be certain that protective grounds are applied before coming within the applicable Minimum Approach Distance of normally energized parts.**
- (5) Shall be certain that an equipotential zone is established before contacting normally energized electrical parts.**
- (6) Shall heed all barriers and guards and obey all warning signs.**
- (7) Shall request a Safety Watcher when one is required in the APM Safety Watching Rules, or the Contractor Safety and Health Requirements for Prime and Subcontractors (CSHRPS)**
- (8) Shall cease work or tests on equipment under the Clearance when the Clearance Holder is not at the job site for electrical work, or the Clearance Holder is not at the substation or unavailable for non-electrical work.**

VI.10 Releasing Clearances

- A. Before releasing a Clearance for work within substations, the Clearance Holder shall perform a pre-Clearance release walkthrough after all work is complete.**
 - (1) The pre-Clearance release walkthrough shall ensure verification of the assurances provided to the Dispatcher or Substation**

Operator to whom the Clearance is to be released, see D. below.

- (2) The Clearance Holder shall be accompanied by one or more of the Electrical Worker Permit holders or Electrical Workers assigned to the job.**
 - (3) Shall be accompanied by the Substation Operator assigned to perform the switching, if present and available.**
- B. All Clearances must be promptly released when the work or test is completed.**
- C. The System Dispatcher may delegate authority to a Substation Operator to accept the release of Dispatcher's numbered Clearances.**
- D. When a Clearance Holder releases a Clearance on a line or equipment that is ready for service, the Dispatcher or Substation Operator must be assured that:**
- (1) All workers and equipment are in the clear.**
 - (2) All portable protective grounds, discharge grounds, and test leads have been removed.**
 - (3) The released line or equipment is ready for service.**
 - (4) All ground switches and isolating devices within the limits of the Clearance have been left in the same position as found.**

When a Clearance is to be released on a line or equipment that is ready for service, the Clearance Holder, or electrical apprentice under the direct on site supervision of the Clearance Holder shall report to the Dispatcher or Substation Operator to whom the Clearance is to be released and shall make a statement similar to the following:

“This is John Doe at Central Substation, and I am ready to release my Test Clearance number D-6789-T on Transformer No. 2. My crew and equipment are in the clear, my portable protective grounds are removed, the work is completed, and as far as I am concerned Transformer No. 2 is ready for service. All ground switches and isolating devices within the limits of the Clearance are in the same position as found.”

The Dispatcher or Substation Operator will repeat back to the Clearance Holder all of the information just provided. **Upon acceptance of the release, the Clearance no longer exists.**

- E. When a Clearance issued by a foreign utility to an individual is released back to the foreign utility, the individual who released the Clearance to the foreign utility shall promptly report the following to the BPA Dispatcher:**
 - (1) Name of foreign utility and the name of the person who accepted release of it**
 - (2) Time released**
 - (3) Foreign utility’s circuit identification**
 - (4) Plans for future needs on the foreign utility’s line or equipment**
- F. Releasing a Clearance on a line or equipment that is NOT ready for service:**
 - (1) Before releasing a Clearance for work within substations, the Clearance Holder shall perform a pre-Clearance release walkthrough to ensure verification of the assurances provided to the Dispatcher or Substation Operator to whom the Clearance is to be released.**
 - (a) The Clearance Holder shall be accompanied by one or more of the**

**Electrical Worker Permit holders or
Electrical Workers assigned to the job.**

- (b) Shall be accompanied by the Substation Operator assigned to perform the switching, if present and available.**
- (2) The Dispatcher or Substation Operator to whom the Clearance is to be released must be assured of the following:**
 - (a) All workers are in the clear.**
 - (b) The condition of the line or equipment.**

The Clearance Holder must advise the Dispatcher or Substation Operator that it is available for limited or emergency service only, or that it is not available for service.
 - (c) The status or location of portable protective grounds, discharge grounds, and test leads.**
 - (d) The plans for a future Clearance on the line or equipment.**
 - (e) The position of ground switches and isolating devices within the limits of the Clearance that is being released.**

When a Clearance is to be released on a line or equipment that is not ready for service, the Clearance Holder, or electrical apprentice under the direct on site supervision of the Clearance Holder shall report to the Dispatcher or Substation Operator to whom the Clearance is to be released and shall make a statement similar to the following:

“This is John Doe at Central Substation, and I am ready to release my Test Clearance number D-6789-T on Transformer No. 2. My crew is in the clear, but Transformer No. 2 is not ready for service. My portable protective grounds are in place on the 230 kV, 115 kV, and 13.8 kV sides of the transformer. The work is scheduled to be continued tomorrow with a

new Test Clearance to be issued to Jim Smith. All ground switches and isolating devices within the limits of the Clearance are in the same position as found.”

The Dispatcher or Substation Operator will repeat back to the Clearance Holder all of the information just provided. **Upon acceptance of the release, the Clearance no longer exists.**

- G. If a Clearance Holder is unable to release a Clearance, the immediate supervisor of that Clearance Holder shall communicate with the crew, release the Clearance, and designate the person who will receive the new Clearance.**

VI.11 Logging Clearances

- A. All switching and tagging done for the issuance and release of a Clearance shall be recorded in the Substation Operating Log.**
- B. Clearances issued by or released to a Substation Operator other than a Dispatcher shall be recorded in red in the Substation Operating Log.**

VII. HOLD ORDERS

VII.1 When Hold Orders are Required

The purpose of a Hold Order is to get personnel in the clear.

- A. Hold Order Is Required:**
 - (1) While performing hot-line work.**
 - (2) While falling danger trees if an electrical hazard could result.**
 - (3) While installing or removing any conductor which crosses over or under normally energized high voltage circuits. If the work cannot be accomplished under the protection**

- of a Hold Order, a Clearance must be obtained.
- (4) While removing or replacing hot-stick links on normally energized high voltage facilities.
 - (5) While proximity work is in progress during line construction.
 - (6) While testing or washing insulators “hot”.
 - (7) While equipment is being operated near energized high voltage facilities and there is the possibility of accidental contact or violation of the applicable Minimum Approach Distance.
 - (8) While performing approved bare-hand procedures.
 - (9) While using the “500 kV All Others” MAD instead of the larger “500 kV Series Caps” MAD on 500 kV lines that have series capacitors installed, when capacitors are bypassed and isolated.

VII.2 Application for Hold Orders

Applications for Hold Orders shall be made in accordance with Switching and Clearance Procedure Section V. Equipment Outages.

When applying for a Hold Order, the following information is to be provided to the Outage Dispatcher.

- A. The correct name designation of the line or equipment requiring a Hold Order, using System Operations numbers and designations.
- B. Whether series capacitors on a 500 kV line are being requested to be bypassed and isolated to allow the use of MAD distances for 500 kV lines without series capacitors.
- C. The date and time the work requiring the Hold Order is scheduled to begin.

- D. The anticipated duration the Hold Order will be required.
- E. The name of the person who will take the Hold Order.
- F. A description of the work to be performed.
- G. The means of communication which will be available during the Hold Order.

VII.3 Issuing and Receiving Hold Orders

The Dispatcher shall order automatic reclosing cutout and tagged, and all other control points tagged for a Hold Order.

When all procedures have been completed for the provisions of the Hold Order, the Dispatcher shall issue the Hold Order to the worker and the hot-line maintenance or proximity work can proceed.

- A. All Hold Orders on the BPA power system shall be issued by a System Dispatcher. Authority to issue Hold Orders may be delegated to a Substation Operator.**

When issuing a Hold Order, the Dispatcher or Operator shall state clearly to the person receiving the Hold Order:

- (1) The name of the person receiving the Hold Order.**
- (2) The exact name of the line or equipment included in the Hold Order.**
- (3) The status of any series capacitors on that line.**

Example: "John Doe, you now have a Hold Order on the John Day-Grizzly No. 1 500 kV Line. The series capacitors at Bakeoven are bypassed and isolated."

- B. Hold Orders will be issued to individuals in the Permit Directory with a Clearance Certification, and to Dispatchers and qualified personnel of foreign utilities or customers.**

When receiving a Hold Order, the recipient of the Hold Order shall repeat back to the Dispatcher or Substation Operator:

- (1) The name of the person receiving the Hold Order.**
- (2) The exact name of the line or equipment included in the Hold Order.**
- (3) The status of any series capacitors on that line.**

Example: "This is John Doe, and I now have a Hold Order on the John Day-Grizzly No. 1 500 kV Line. The series capacitors at Bakeoven are bypassed and isolated."

The Dispatcher or Operator and the recipient of the Hold Order shall confirm the location of the crew and the communication which will be available for the duration of the Hold Order.

- C. When crews require a Hold Order for work on lines or equipment under foreign utility jurisdiction, they will receive Hold Orders in accordance with the foreign utility's rules and procedures.**
- D. A Hold Order issued to an individual by a foreign utility on their line or equipment is issued according to that utility's rules and procedures. This process is accomplished by either of the following:**
- (1) The BPA Dispatcher can receive the Hold Order from the foreign utility and in turn issue a Hold Order to the individual, or**

(2) The Hold Order can be issued directly to an individual from the foreign utility.

(Refer to BPA Work Standard BPA-WS-3-5, Clearances and Hold Orders from Foreign Utilities, for an example and discussion of each process.)

When crews require Hold Orders on lines or equipment under a foreign utility's jurisdiction for proximity work on a BPA project, the BPA Dispatcher will issue the Hold Order, except in those cases where the foreign utility's rules and procedures dictate that the utility will issue the Hold Order.

Or

In those cases where the foreign utility's determination is to issue directly to an individual, the recipient of the Hold Order from the foreign utility shall promptly inform the BPA Dispatcher of the following upon receipt of the Hold Order and before beginning work requiring the protection of a Hold Order:

- (a) Name of foreign utility and the name of the person who issued it**
- (b) Time received**
- (c) Foreign utility's circuit identification work location with respect to BPA transmission line**
- (d) Date, time and duration of Hold Order on the foreign utility's line or equipment**

VII.4 Provisions of a Hold Order

With the issuance of a Hold Order, the Dispatcher or Substation Operator gives assurance that:

- A. Protective relays are in service at all terminals, which will adequately protect the circuit for all types of faults.**
- B. Automatic reclosing of power circuit breakers that protect the line or equipment has been disabled by manually placing or checking the reclosing relay cutout switch in the “off” position, or Automatic reclosing and the close circuits* of the power circuit breaker(s) that protect the line or equipment have been disabled or checked disabled remotely by a System Dispatcher.**

*Close circuits that would prevent the closing of the PCB(s) at the station by the control switch. SCADA will have full operational control of the PCB(s) while the Hold Order is in place.

- C. An “Assurance of no backfeed” or a “Terminal Hold” has been obtained on all interconnections with a customer or foreign utility.**
- D. All control points have been properly tagged to prevent energization of the lines or equipment included in the Hold Order if they are de-energized by terminal relay action.**
- E. The lines or equipment will not be energized until the Holder of the Hold Order reports the crews in the clear.**
- F. If the Hold Order is requested on a 500 kV line with series capacitors bypassed to allow the use of MAD distances for 500 kV lines without series capacitors, all series capacitors on that line have been bypassed, isolated and properly tagged.**

VII.5 Hold Order Responsibilities

- A. The person receiving the Hold Order:**
 - (1) Shall know the exact name of the line or equipment included in the Hold Order. That person shall also know the time of issue, and**

the name of the Dispatcher or Substation Operator who issued the Hold Order.

- (2) Shall verbally convey this information to all persons working under that Hold Order.
- (3) Shall direct installation of barriers or guards as necessary to prevent accidental contact with adjacent energized facilities before allowing work to begin in areas where such hazards exist.
- (4) Shall utilize Safety Watchers as required in the APM Safety Watching Rules, or the Contractor Safety and Health Requirements for Prime and Subcontractors (CSHRPS). Hold Orders do not modify Safety Watcher requirements.
- (5) Shall remain at the job site with the workers while the work requiring the protection of the Hold Order is being completed.
- (6) Shall maintain a method of communicating with the Dispatcher for the duration of the Hold Order.
- (7) Shall call the crew into the clear and notify the Dispatcher if an energized facility becomes de-energized for any reason.

B. The Workers

- (1) Shall know the exact name of the line or equipment included in the Hold Order. The Workers shall verbally acknowledge to the person receiving the Hold Order, the time of issue, and the name of the Dispatcher or Substation Operator who issued the Hold Order.
- (2) Shall heed all barriers and guards, and obey all warning signs.

- (3) Shall request a Safety Watcher when one is required in the APM Safety Watching rules, or the Contractor Safety and Health Requirements for Prime and Subcontractors (CSHRPS). Hold Orders do not modify Safety Watcher requirements.
- (4) Shall limit their movements and perform work in a manner that will prevent applicable Minimum Approach Distances from being violated.
- (5) Shall get in the clear and report to the person having the Hold Order if an energized facility becomes de-energized for any reason.

C. Dispatchers and Switchmen

If any power circuit breaker (PCB) tagged for a Hold Order opens automatically while the Hold Order is in effect:

- (1) The Switchman shall notify the Dispatcher immediately.
- (2) The Dispatcher shall communicate with the crew having the Hold Order.

If the person having the Hold Order reports the crew is “in the clear”, the Dispatcher may order the PCBs closed. This is permitted without the release of the Hold Order.

VII.6 Releasing Hold Orders

- A. All Hold Orders must be promptly released when the work is finished.
- B. When a worker releases a Hold Order, the Dispatcher must be assured that:
 - (1) All workers and equipment are in the clear.
 - (2) The work is finished for the day or the job is completed.

When a Hold Order is to be released, the person having the Hold Order shall report to the Dispatcher or Operator to whom the Hold Order is to be released and shall make a statement similar to the following:

“This is John Doe, and I am ready to release my Hold Order on the Central-East Columbia No. 3 230 kV Line. My crew and equipment are in the clear and the work is complete.”

The Dispatcher will repeat back to the person releasing the Hold Order all of the information just provided. **Upon acceptance of the release, the Hold Order no longer exists.**

- C. When a Hold Order issued by a foreign utility to an individual is released back to the foreign utility, the individual who released the Hold Order to the foreign utility shall promptly report the following to the BPA Dispatcher:**
 - (1) Name of foreign utility and the name of the person who accepted release of it**
 - (2) Time released**
 - (3) Foreign utility’s circuit identification**
 - (4) Plans for future needs on the foreign utility’s line or equipment**
- D. If a worker is unable to release a Hold Order, the immediate supervisor of that worker shall communicate with the crew, release the Hold Order and designate the person who will receive the new Hold Order.**

VII.7 Logging Hold Orders

- A. Hold Orders issued by or released to a Substation Operator shall be recorded in red in the Substation Operating Log.**

- B. All switching and tagging done for the issuance and release of Hold Orders shall be recorded in the appropriate logs.**

VIII. WORK PERMITS

VIII.1 When Work Permits are Required

Work Permits are required for all work on power system equipment (including fiber) under the jurisdiction of Operations not requiring a Clearance or a Hold Order but affecting the operation or protection of the power system or substation.

VIII.2 Application for Work Permits

Applications for Work Permits shall be made in accordance with Switching and Clearance Procedure Section V, Equipment Outages.

VIII.3 Issuing and Receiving Work Permits

- A. All Work Permits on the BPA power system shall be issued by a System Dispatcher or Substation Operator.**

When issuing a Work Permit, the Dispatcher or Substation Operator shall state clearly to the person receiving the Work Permit:

- (1) The name of the person receiving the Work Permit.**
- (2) The exact name of the line or equipment included in the Work Permit.**

Example: “John Doe, you now have a Work Permit at Grizzly on PCB 4042 compressor system.”

- B. Work Permits will be issued to:**

- (1) A qualified person, as determined by their supervisor.**

NOTE: To be considered an approved contractor Work Permit holder in the Permit

Directory, contract personnel must be approved in accordance with BPA Work Standard BPA-WS-3-9, Approving Contractors to Hold Work Permits.

(2) Qualified persons of foreign utilities.

When receiving a Work Permit, the recipient of the Work Permit shall repeat back to the Dispatcher or Substation Operator:

- (1) The name of the person receiving the Work Permit.**
- (2) The exact name of the line or equipment included in the Work Permit.**

Example: "This is John Doe, and I now have a Work Permit at Grizzly on PCB 4042 compressor system."

VIII.4 Work Permit Responsibilities

A. The person receiving the Work Permit:

- (1) Shall know the exact name of the line or equipment included, the time of issue, and the name of the Dispatcher or Substation Operator who issued the Work Permit.**
- (2) Shall verbally convey this information to all persons working under the Work Permit.**
- (3) For work in substations, shall remain at the substation while work requiring the Work Permit is being completed. If the purpose of the Work Permit is for end-to-end terminal work, such as for relay or communications equipment, the holder of the Work Permit shall be at one of the terminals where work is occurring under the Work Permit.**
- (4) For work on transmission lines, shall remain at the location where the work requiring the Work Permit is located.**

- (5) **Shall maintain a method of communication with the Dispatcher or Substation Operator for the duration of the Work Permit.**

VIII.5 Releasing Work Permits

- A. All Work Permits must be promptly released when the work is completed.**
- B. When a person releases a Work Permit, the Dispatcher or Substation Operator must be told the status of the equipment, i.e. the equipment is ready for service or the equipment remains out of service.**

When a Work Permit is to be released, the person having the Work Permit shall report to the Dispatcher or Substation Operator, and shall make a statement similar to the following:

“This is John Doe, and I am ready to release my Work Permit on Grizzly PCB 4042 compressor system. My work is complete for the day and the equipment is ready for service.”

The Dispatcher will repeat back to the person releasing the Work Permit all of the information just provided. **Upon acceptance of the release, the Work Permit no longer exists.**

- C. If the holder of the Work Permit is unable to release a Work Permit, the immediate supervisor of that Work Permit holder shall communicate with the crew, release the Work Permit and designate the person who will receive the new Work Permit.**

VIII.6 Logging Work Permits

The issuance, release and associated switching for Work Permits shall be logged in the Substation Operating Log in the exact order performed.

IX. LOW VOLTAGE CIRCUITS, EQUIPMENT AND ENERGY STORAGE SYSTEMS

- A. Permission shall be obtained before any low voltage circuits, equipment, or energy storage systems affecting the operation or protection of the power system (Dispatcher) or substation (Operator) are deenergized or made unavailable for normal service.**
- B. Applications for Work Permits shall be made in accordance with Section V, Equipment Outages.**
- C. The Work Permit holder and/or Authorized Employee:
 - (1) May energize or de-energize as required to complete the work unless tagged with a Do Not Operate Tag.**
 - (2) Shall coordinate energizing or de-energizing with the Dispatcher/Operator in those cases where the Dispatcher/Operator has determined operation or protection of the power system or substation could be adversely impacted or further switching is necessary prior to energization.**
 - (3) Obtain permission from a Dispatcher or Operator before restoring to normal service.****
- D. Work performed and associated switching shall be logged in the Substation Operating Log in the exact order performed.**

Placement and/or removal of Lockout/Tagout devices and LOTO Do Not Operate tag(s) are not logged.

Reference APM Rule L-3, Lockout/Tagout and BPA Work Standard BPA-WS-8-1, Lockout/Tagout, for Lockout/Tagout rules and procedures.

X. TAGGING

X.1 Types of Tags

Accident Prevention Tags used on the BPA System are either standard size or miniature size.

A. Standard size tags are 3 ½" x 5 ¾".

- (1) The red Do Not Operate tag (BPA F 6510.11) is pictured on page A-1.

Do Not Operate tags are used to tag:

- (a) Isolating devices that are the limits of a Clearance on high voltage facilities.
- (b) Devices that may energize low voltage circuits which are de-energized and not to be operated.
- (c) Open switches which are not to be operated without specific permission of the Dispatcher or Substation Operator.

Clearances, Hold Orders and Work Permits may be issued against a Dispatcher's Do Not Operate tag on an open isolating device.

- (2) The yellow Hold Order tag (BPA F 6510.28) and remote Hold Order amber light and yellow Hold Order placard are pictured on pages A-1 and A-2.

Hold Order tags are used to tag control points associated with a Hold Order.

Remote Hold Order amber light and yellow Hold Order placard are used to tag all control points associated with Dispatcher controlled remote Hold Orders.

- (3) The yellow on white Caution tag (BPA F 6510.12) is pictured on page A-3.

Caution tags are used to tag equipment or controls that are abnormal, unusual, unsafe or hazardous.

- (4) The white Work Permit tag (BPA F 6510.13) is pictured on page A-2. Work Permit tags are used to tag:
 - (a) High voltage power system equipment or circuits that are being worked on including equipment that has been de-energized for induced voltage reduction when the protection of a Clearance or a Hold Order is not required, and applicable Minimum Approach Distances will not be violated.
 - (b) Fiber optic circuits for work.
 - (c) Low voltage power system equipment or circuit work.

B. Miniature size tags are 1 ½" x 1" or 1 ¾" diameter round and are pictured on page A-4.

- (1) Red with black border Do Not Operate tag (BPA F 6510.14)
- (2) Red Work Clearance tag (BPA F 6510.15)
- (3) Blue Test Clearance tag (BPA F 6510.16)
- (4) Yellow Caution tag (BPA F 6510.17)
- (5) Round yellow Hold Order tag (BPA F 6510.18)
- (6) White Work Permit tag (BPA F 6510.19)

Miniature size tags are used to tag:

- (1) Group display boards in control centers
- (2) Diagram (pin) boards in substations
- (3) The mimic bus of switchboard control panels
- (4) Miniature switchboard controls

- C. The blue Electrical Test Marker (BPA F 6510.40) is pictured on page A-3.

Electrical Test Markers are used to indicate points of separation on equipment which will be electrically tested under a Work Clearance.

- D. The red wooden block is pictured on page A-5.

Red wooden blocks are used as tag holders and as indicators of switches or equipment which are in abnormal positions as described in the following sections.

X.2 Tagging for Clearances

- A. Isolating devices used as a limit of a Clearance shall be opened, rendered inoperable (if its design permits) and tagged before the Clearance is issued.**

When communicating with the Dispatcher, a statement that the specific isolating devices are open and tagged is sufficient. This assurance to the Dispatcher is understood to include that the Switchman has performed the necessary steps to ensure the isolating devices meet the requirement of this section.

Additional information on rendering specific devices inoperable can be found in BPA Work Standard BPA-WS-3-1, Switching Process.

- B. Red Do Not Operate tags shall be placed on all isolating devices used as a limit of a Clearance before the Clearance is issued.**

Specific methods of tagging and rendering isolating devices inoperable shall be included in Station Instructions.

Additional tagging information can be found in BPA Work Standard BPA-WS-3-1, Switching Process.

Example 1:

Assume a Work Clearance is requested for transmission line maintenance on the Central-East Columbia No. 3 230 kV line in the following illustration.

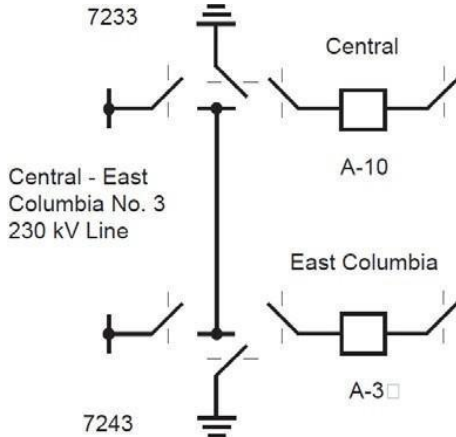

Normal Dispatching/SCADA operating procedures would de-energize the Central-East Columbia No. 3 230 kV line by opening PCBs A-10 and A-3 by supervisory control.

A Switchman at each terminal of the line would write a Switching Order to place the appropriate PCB on Local control and to open or check open and tag the appropriate disconnect switches. The ground switches at both terminals would remain open, unless otherwise agreed to by the Clearance applicant and the Dispatcher.

Central Substation terminal is equipped with a mimic bus on the switchboard control panels. Tagging at that terminal would be as follows:

The Supervisory Cutout Switch (SCS) for A-10 PCB will be placed in the Local position and a "Local" marker attached. In the switchyard, the Switchman will check open, and tag A-10 Auxiliary Bus Disconnect and open and tag A-10 Line Side

Disconnect with red Do Not Operate tags checked
“See Tag on A-10 Control Panel.”

In the control house, the Switchman will tag the mimic bus A-10 Line Side Disconnect and A-10 Auxiliary Bus Disconnect with miniature red Work Clearance tags. The Switchman will fill out and place on the A-10 control panel the master red Do Not Operate tag containing all necessary information.

East Columbia Substation terminal has no mimic bus on the switchboard control panels. Tagging at that terminal would be as follows:

The SCS for A-3 PCB will be placed in the Local position and a “Local” marker attached. In the switchyard, the Switchman will check open, and tag A-3 Auxiliary Bus Disconnect with a red Do Not Operate tag checked “See Tag on A-3 Line Side Disc”. The Switchman will open and tag A-3 Line Side Disconnect with the filled out master red Do Not Operate tag containing all necessary information.

Note that at both substations there is only one filled out master tag for the switching and tagging done at that station for this Clearance.

At the control center, the Dispatcher will pin the group display board with white pins in the isolating devices which are open and tagged as the limits of this Clearance and with a miniature red Work Clearance tag containing the Clearance Holder’s name and Clearance number. If any ground switches associated with the Clearance are closed, the Dispatcher will pin them with red pins and white disks.

Example 2:

Assume a Test Clearance is also requested on A-10 PCB for maintenance during the time the Central-East Columbia No. 3 230 kV line is out of service on a Work Clearance. A-10 PCB is already open and on Local control with a "Local" marker attached to the SCS.

The Switchman at Central Substation would write a Switching Order to open or check open and tag the appropriate disconnect switches.

In the switchyard, the Switchman will check open and tag A-10 Line Side Disconnect and open and tag A-10 Main Bus Disconnect with red Do Not Operate tags checked "See Tag on A-10 Control Panel".

In the control house, the Switchman will tag the mimic bus A-10 Line Side Disconnect and A-10 Main Bus Disconnect with miniature blue Test Clearance tags.

The Switchman will fill out and place on the A-10 control panel the master red Do Not Operate tag containing all necessary information.

At the control center, the Dispatcher will pin the group display board with white pins in the isolating devices which are open and tagged as the limits of this Clearance, and with a miniature blue Test Clearance tag containing the Clearance Holder's name and Clearance number.

Example 3:

Example 3 explains the tagging of isolating devices that are limits of a Clearance where there are multiple Clearances on the same equipment.

Assume that the foremen of two different crews each have a Work Clearance on the same PCB shown below, so the isolating devices used as the limits of both Clearances are the same. Only one Do Not Operate tag would be hung on each of the isolating devices. The Do Not Operate tag would not be removed until after both Clearances are released.

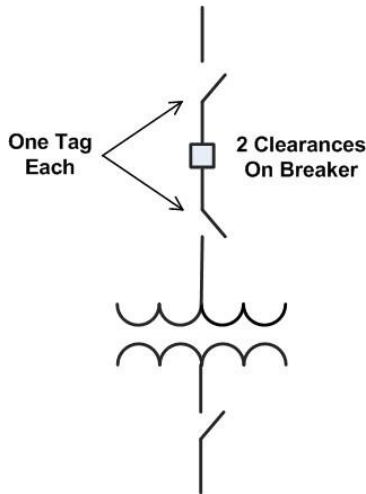

Example 4:

Example 4 explains the tagging of isolating devices that are limits of a Clearance where there are two adjacent Clearances with a common Clearance limit that is shared between the two adjacent Clearances.

One Clearance is issued on a transformer bank. A second Clearance is issued on the transformer bank PCB. The disconnect switch between the transformer bank and the PCB is the isolating device that is a Clearance limit common to both Clearances. (Refer to the following drawing). The common Clearance limit would have two Do Not Operate tags hung on it.

The other disconnect switches would each have one Do Not Operate tag hung on them. When one of the two Clearances is released, one of the two Do Not Operate tags on the common Clearance limit would be removed. After the other Clearance is released, the remaining Do Not Operate tags would be removed.

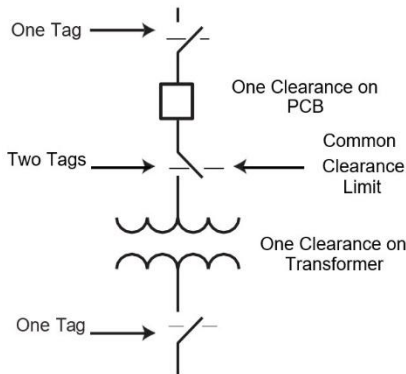

If two Clearances are issued on the PCB and one Clearance on the transformer bank, two Do Not Operate tags would be hung on the common Clearance limit. The other disconnect switches would each have one Do Not Operate tag hung on them. (Refer to the following drawing).

If one of the Clearances on the PCB is released first, none of the Do Not Operate tags would be removed. If the Clearance on the transformer bank was released first, one of the two Do Not Operate tags on the common Clearance limit and the Do Not Operate tag on the other disconnect switch associated with the Clearance on the transformer bank would be removed. When the last Clearance is released all remaining Do Not Operate tags would be removed.

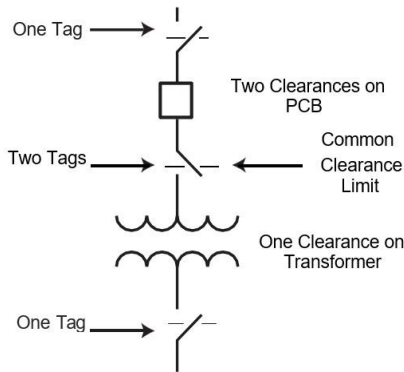

Example 5:

Assume that a Work Clearance is requested for Transformer Bank No. 1 including the Station Service transformer bank as illustrated in the following drawing. A-9 Transformer Side and Auxiliary Bus and B-2 Transformer Side and Auxiliary Bus Disconnect switches will be tagged as Clearance limits with Do Not Operate tags. For the purposes of controlling energization of the equipment included within the Clearance from the alternate station service source, a Do Not Operate tag shall also be placed on the open low voltage isolating device ACB-1 as a Clearance limit.

If work is to be performed on the low voltage equipment included within the Clearance limits, appropriate Lockout/Tagout procedures shall be followed.

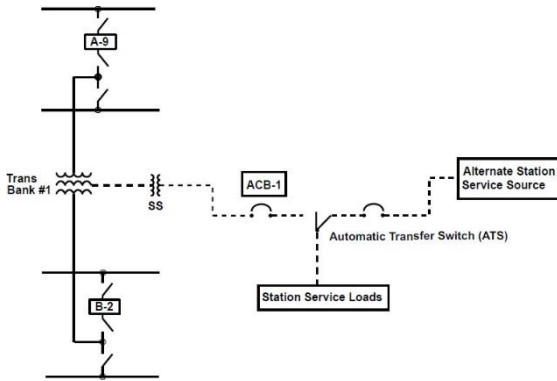

If space or location will not allow a large red Do Not Operate tag to be placed on the low voltage isolating device, a filled out miniature red Do Not Operate tag or tags may be placed on the device and the master tag containing all pertinent information placed in a convenient and conspicuous location.

X.3 Tagging for System Dispatcher or Substation Operator

A System Dispatcher or Substation Operator shall, when necessary, order a red Do Not Operate tag for the Dispatcher or Substation Operator placed on an open isolating device to prevent its operation. Where design permits, those isolating devices shall be rendered inoperable prior to tagging.

A Clearance may be issued on lines or equipment if the isolating devices are open, rendered inoperable (if the design permits) and tagged for the Dispatcher and/or Operator.

Example 1:

Assume trouble occurs with a 13.8 kV self-contained power circuit breaker (“oil-recloser”) at a small substation shown below. The Dispatcher could direct a Switchman to write a Switching Order to bypass and isolate the PCB and tag the disconnects on both sides of the PCB for the System Dispatcher.

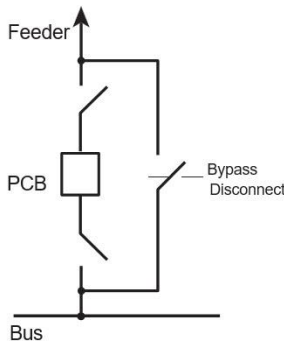

The Switchman would tag the open hot-stick operated Bus Disconnect and Feeder Disconnect with red Do Not Operate tags which are attached to red wooden blocks and checked “See Tag in the PCB control cabinet”.

A fully filled out master red Do Not Operate tag containing all necessary information would be placed in the control cabinet of the PCB.

X.4 Releasing System Dispatcher or Substation Operator Tags

When a System Dispatcher or Substation Operator is releasing their red Do Not Operate tag on an open isolating device, the System Dispatcher or Substation Operator shall make a statement similar to the following:

“This is _____ and I am releasing my System Dispatcher’s or Substation Operator’s tag on _____. There are no outstanding Clearances issued against my tag.”

Isolating devices tagged with red Do Not Operate tags shall not be operated until the tag has been removed by an approved Switching Order.

X.5 Tagging for Abnormal, Unusual, Unsafe or Hazardous Conditions

A large yellow on white or miniature yellow Caution tag must be placed on equipment or controls to warn about abnormal, unusual, unsafe, or hazardous conditions.

Example 1:

Assume a 230 kV Transformer PCB is to be bypassed, cleared, and tagged for substation maintenance. Current Transformer connections require that the Transformer Differential relays be out of service during the entire time that the Auxiliary Bus Disconnect is closed.

The Switchman will place a yellow on white Caution tag checked “See Tag on relay panel no. xx” on the control switch of the bypassed PCB denoting that an abnormal condition exists. A fully filled out master yellow on white Caution Tag will be placed on that relay panel on the Transformer Differential relays that are out of service.

Example 2:

Assume one PCB in a bay of a breaker-and-a-half configuration has been determined to be inadequate for line-dropping.

Protective relay schemes have been modified to prevent this PCB from being the last one to open by relay operation, and tagging is deemed necessary to prevent inadvertent line dropping during routine switching.

The Switchman may be directed to place a yellow on white Caution tag on the control switch of the PCB. If, as in many newer 500 kV substations, miniature control panels are installed, a miniature yellow Caution tag will be placed on the control switch stating the precaution and the date. In a convenient location adjacent to the control panel, a fully filled out large master yellow on white Caution tag will be placed.

At the control center, the group display board may be tagged with a miniature yellow Caution tag advising of the unusual operating restriction on this PCB, and the date.

Example 3:

Assume that the Load-Break Disconnect (LBD) to a section of a 230 kV grounded-wye capacitor group is open, cleared, and tagged for maintenance work. The other sections of the capacitor group will remain in service or available for service.

Before the Clearance is issued, all automatic voltage controls on 230 kV shunt capacitors at that substation will be placed in the manual mode, and yellow on white Caution tags will be placed on the control switches of the PCBs or LBDs of all other 230 kV capacitor sections at that substation stating,

“Notify workers to stand clear before closing this switch.”

If the substation remains on supervisory control, the control center will also tag these controls in a similar manner.

X.6 Tagging for Hold Orders

Yellow Hold Order tags for a Hold Order must be placed on all associated control points and round yellow Hold Order tags must be placed on reclosing relay cutout switches before the Hold Order is issued.

Example 1:

Assume a Hold Order for maintenance is to be issued on the Central-Oceanside No. 1 500 kV line illustrated below.

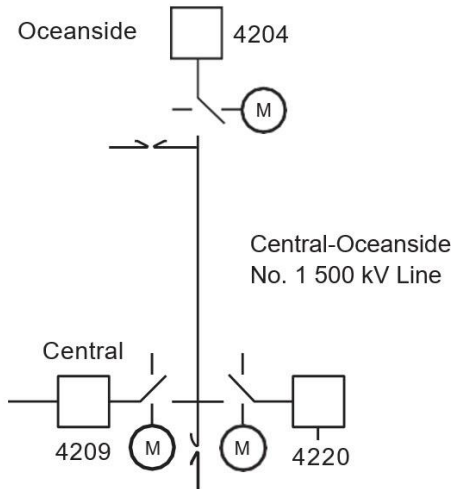

The Dispatcher will contact a Switchman at each terminal and request the reclosing relays cutout on PCBs 4209 and 4220 at Central Substation and on PCB 4204 at Oceanside Substation, and the reclosing relays and each PCB control switch be tagged with a Hold Order for the Dispatcher.

At Central, the Switchman will place the reclosing relay cutout switch on PCBs 4209 and 4220 to the off position and tag each with a round yellow Hold Order tag for the

Dispatcher. The Switchman will also tag each PCB control switch with a yellow Hold Order tag for the Dispatcher and report to the Dispatcher.

At Oceanside, the Switchman will place the reclosing relay cutout switch on PCB 4204 to the off position and tag with a round yellow Hold Order tag for the Dispatcher. The Switchman will also tag the PCB control switch with a yellow Hold Order tag for the Dispatcher and report to the Dispatcher.

The Dispatcher tags the supervisory control points for the PCBs with a Hold Order tag. The Dispatcher issues the Hold Order to the worker and then tags the line or facility on the group display board with a round yellow Hold Order tag for the worker.

Example 2:

Tagging for a Hold Order at a substation where the reclosing relay can be remotely cutout from a control center.

Referring to the drawing in Example 1, assume a Hold Order is to be issued for tree removal on the Central-Oceanside No. 1 500 kV line illustrated above.

At Central, the Switchman will place the reclosing relay cutout switch on PCBs 4209 and 4220 to the off position and tag each with a round yellow Hold Order tag for the Dispatcher. The Switchman will also tag each PCB control switch with yellow Hold Order tag for the Dispatcher and report to the Dispatcher.

The Dispatcher would initiate via a single point selection from the SCADA display screen and initiate a command to disable the reclosing relay and the local close bus to PCB 4204 at Oceanside Substation. The Dispatcher will receive a change of status indication on the display screen confirming that the command was received and completed.

At Oceanside, an amber lamp next to the PCB control switch will be illuminated indicating the reclosing relay is

disabled. Additionally, the close bus indication lamp to PCB 4204 at Oceanside will not be illuminated indicating that it is disabled. If the substation has an HMI, the screen will also show the reclosing relay cutout, a remote Hold Order in effect and an amber light illuminated on each associated line relay. This will constitute a Hold Order tag for the Dispatcher at Oceanside.

Although not preferred, a local Hold Order may also be put in place with Dispatcher approval at a remote Hold Order enabled site. At Oceanside using an HMI, PCB 4204 reclosing is cutout on screen and tagged with a round yellow Hold Order tag and the control point is tagged with a Hold Order tag and reported to the Dispatcher. An amber light would illuminate on each associated line relay and the close bus indication would not be illuminated. This will constitute a Hold Order tag for the Dispatcher at Oceanside.

X.7 Isolating Series Capacitors for Reduced MAD for Hold Orders

Assume series capacitors on the 500kV line illustrated below have been bypassed, isolated and properly tagged for a Hold Order to allow the use of MAD distances for 500 kV lines without series capacitors. The tagging would be as follows:

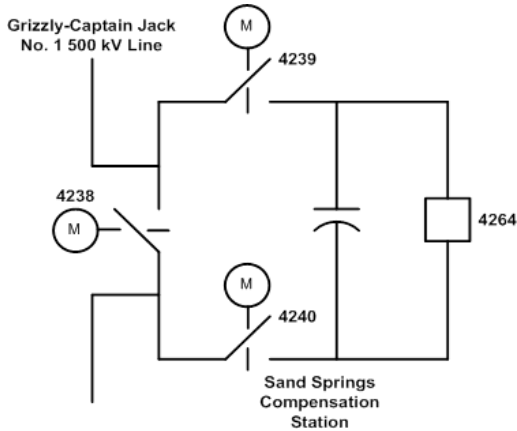

At Sand Springs:

- A. Bypass MOD 4238 would be closed.
- B. MODs 4239 and 4240 would be opened, rendered inoperable (if design permits) and tagged with a red Do Not Operate tag checked "See Tag On control panel mimic bus."
- C. On the control panel mimic bus MODs 4239 and 4240 would be tagged with miniature red Do Not Operate tags for the Dispatcher. A large fully filled out red Do Not Operate tag for the Dispatcher would be placed on the mimic bus close to either disconnect.

At the control center the Dispatcher will pin the group display board with white pins and miniature tags in the MODs that are open and tagged for the Dispatcher.

X.8 Tagging for Work Permits

A white Work Permit tag shall be placed on:

- A. Affected equipment or circuits when a Work Permit is issued for work at locations other than microwave sites**
- B. Affected equipment or circuits at microwave sites when the work will not be completed before the worker leaves the worksite.**
- C. Isolating devices which have been opened to facilitate work not requiring a Clearance or a Hold Order (see example 2).**

Example 1:

Assume work is to be done on the Microwave Transfer Trip (MWTT) relaying of a three terminal 230 kV line.

Tone Test switches (TTS) at all three terminals will be turned to the “off” position and tagged with a white Work Permit tag for John Doe. PCB control switches at each terminal will be tagged with a white Work Permit tag checked “See Tag on relay panel no. XX”.

Example 2:

Assume work is to be done on the operating mechanism of a 230 kV PCB and it has been determined that a Clearance is not required.

The PCB will be isolated from the power system by open isolating devices. In the switchyard, the open disconnect switches will be tagged with a white Work Permit tag checked “See Tag on PCB A-XXX control switch”. The control switch for the PCB will be tagged with a fully filled out master white Work Permit tag for John Doe.

At the control center, the group display board will be tagged with miniature white Work Permit tags in both Examples 1 and 2.

Example 3:

Assume work is to be done on power system equipment at a microwave site and the work is completed before the worker leaves the worksite.

No Work Permit tag will be required.

Example 4:

Assume work is to be done on power system equipment at a Microwave Site; and that the work is not completed before the worker leaves the worksite.

The equipment will be tagged with a Work Permit tag for the worker.

D. Isolating devices which have been opened to facilitate work on low voltage circuits, equipment, and energy storage systems (see example 5 below).

Example 5:

Assume a 230 kV PCB is bypassed over a Bus Tie PCB and a Work Clearance has been issued for trouble on the compressor system.

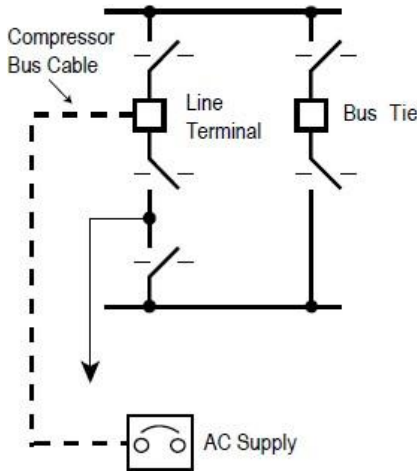

During the course of work a maintenance worker decided the compressor bus cable is needed in order to make repairs and requests the compressor bus cable de-energized. Permission from the appropriate System Dispatcher is obtained and the compressor bus cable supply ACB is cutout and tagged with a Work Permit tag for the requestor. A Work Permit is then issued to the requestor. Any Authorized Employee who is to perform work involving the compressor bus cable would follow APM Rule L-3 and BPA Work Standard BPA-WS-8-1, Lockout/Tagout.

X.9 Tagging for De-Energized Low Voltage Circuits

Red Do Not Operate tags may be placed on low voltage isolating devices to prevent their operation.

Example:

Assume a compressor bus cable is cutout on a Work Permit for repairs in one bay of a Breaker and a Half scheme. The Operator may place a filled out red Do Not Operate tag for the Operator on the supply ACB in addition to the Work Permit tag to control its operation due to branch circuits. If more than one source of power must be opened, the other tags will be checked “See Tag on (location of master tag).”

If space or location will not allow a large red Do Not Operate tag to be placed, a filled out miniature red Do Not Operate tag or tags may be placed and the master tag containing all pertinent information placed in a convenient and conspicuous location.

X.10 Electrical Test Markers

Blue Electrical Test Markers must be placed on all high voltage conductors attached to a piece of equipment being tested under a Work Clearance as close to the point of separation as possible.

Example:

Assume a Work Clearance has been issued to a Substation Maintenance Crew and a Transmission Line Maintenance Crew on the Markim Main Bus, A-12 PCB and the Central-Markim 230 kV Line, illustrated below. The limits of the Clearance are A-10 Main Bus Disconnect, A-12 Auxiliary Bus Disconnect at Markim and A-14 Line Side Disconnect and Auxiliary Bus Disconnect at Central.

The line crew will be changing insulators on the Central-Markim Line. Substation Maintenance will perform routine maintenance on A-12 Main Bus and Line Side Disconnects, a mechanism service on A-12 PCB, and test the Main Bus PTs at Markim.

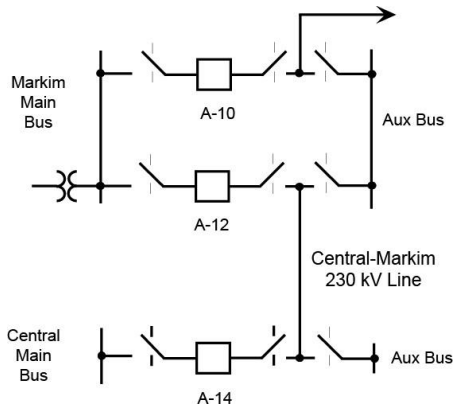

Prior to performing a millivolt drop test on A-12 PCB, as part of the mechanism service, the Clearance Holder for the Substation Maintenance Crew would open A-12 Main Bus and Line Side Disconnects and lock them open to provide separation of the PCB from the rest of the high voltage equipment in the Clearance. The Clearance Holder would then attach the blue Electrical Test Markers on each phase of the bus on the breaker side near each open disconnect.

The Clearance Holder would then notify any other Clearance Holders in the immediate area that the electrical tests will be performed on A-12 PCB. The Clearance Holder would then perform or directly supervise the millivolt drop test. Once the test was complete, the Clearance Holder would then remove all blue Electrical Test Markers and notify any other Clearance Holders in the immediate area that the electrical tests on A-12 PCB are complete. Once the tests are complete and the blue Electrical Test Markers are removed, A-12 Main Bus and Line Side Disconnects may be operated at the will of the Clearance Holder.

Prior to performing electrical tests on the Main Bus PTs, the Clearance Holder would direct the crew to remove or disconnect and tie back the conductor from the Main Bus to each PT which would be tested. The Clearance Holder would then attach the blue Electrical Test Marker to the top of each PT to be tested. The Clearance Holder would then notify any other Clearance Holders in the immediate area that electrical tests will be performed on the Main Bus PTs. The Clearance Holder would then perform or directly supervise the electrical tests. Once the tests are complete, the Clearance Holder would remove the blue Electrical Test Markers from each of the PTs which were tested and notify any other Clearance Holders in the immediate area that electrical tests on the PTs are complete. Installation of the conductor from the Main Bus to the PTs could then be done at the will of the Clearance Holder.

The intent of the placement of the blue Electrical Test Markers is to visually outline the electrical equipment which is being tested under a Work Clearance. While the methods outlined above are the prescribed way of placing the blue Electrical Test Markers, it is realized that the numerous conditions of separating equipment may produce a situation where strict adherence to the prescribed method of hanging the blue Electrical Test Markers may interfere with the electrical tests being performed. In those instances, the Clearance Holder should place the blue Electrical Test Markers in a way which will most closely follow the prescribed rules and the intent of visually outlining the equipment being tested.

XI. COLOR ADDENDUM

A low-angle photograph of a bright sun shining through trees, creating a starburst effect with colorful lens flares against a deep blue sky. The sun is positioned in the lower right quadrant, and its rays fan out across the frame. The trees are silhouetted against the sky, with some leaves catching the light. The overall mood is serene and vibrant.

PHOTO BY ANTHONY WILLBANKS

Do Not Operate Tag (BPA F 6510.11)



Hold Order Tag (BPA F 6510.28)



Caution Tag
(BPA F 6510.12)

(FRONT) (BACK)

FRONT

BPA 6510.12 (8-06)
US DEPARTMENT OF ENERGY
BONNEVILLE POWER ADMINISTRATION

CAUTION

DO NOT REMOVE THIS TAG WITHOUT AUTHORIZATION

FOR DATA
 SEE OTHER SIDE
 SEE TAG ON _____

BACK

BPA 6510.2812 (8-06)

CAUTION

STATION/LOCATION _____
EQUIPMENT/CIRCUIT _____

SWITCHES/DEVICES TAGGED _____











TAGGED FOR _____
CONDITIONS/REASON _____

TAG PLACED BY _____
hrs | date _____
TAG REMOVED BY _____
hrs | date _____

Electrical Test Marker
(BPA F 6510.40)

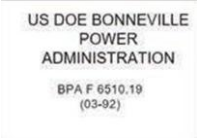
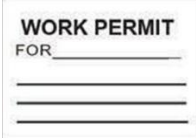

Miniature Tags

 <p>US DOE BONNEVILLE POWER ADMINISTRATION DO NOT OPERATE BPA F 6510.14 (03-92)</p>	<p>Red Do Not Operate Tag with black border (BPA F 6510.14)</p>	 <p>DO NOT OPERATE FOR _____ DATE _____</p>
 <p>TEST CLEARANCE BPA F 6510.16 (01-91)</p>	<p>Blue Test Clearance Tag (BPA F 6510.16)</p>	 <p>TEST CLEARANCE FOR _____ NO. _____</p>
 <p>WORK CLEARANCE BPA F 6510.15 (05-91)</p>	<p>Red Work Clearance Tag (BPA F 6510.15)</p>	 <p>WORK CLEARANCE FOR _____ NO. _____</p>
 <p>BPA F 6510.17 (03-92)</p>	<p>Yellow Caution Tag (BPA F 6510.17)</p>	 <p>CAUTION _____ _____ DATE _____</p>
 <p>BPA F 6510.18 (03-92)</p>	<p>Yellow Hold Order Tag (BPA F 6510.18)</p>	 <p>HOLD ORDER FOR _____</p>
 <p>US DOE BONNEVILLE POWER ADMINISTRATION BPA F 6510.19 (03-92)</p>	<p>White Work Permit Tag (BPA F 6510.19)</p>	 <p>WORK PERMIT FOR _____ _____ _____</p>

Red Wooden Block

Catalog ID: 0000197930





PHOTO BY NICHOLAS CURRY-MACIEL

AT THE JOB SITE INTERPRETATIONS

The holder of a Clearance or Hold Order shall remain At the Job Site, physically with the workers, at the location where the work is being performed during the time any active work is being performed on lines or equipment under the protection of a Clearance or Hold Order, or all work must stop. The type of work the crew is performing (i.e. on the ground, in the air, or in a cabinet) does not change or modify this requirement.

NOTE: Issuing a Work Permit on lines or equipment included in a Clearance or Hold Order is not authorized to allow crews to continue working when the holder of the Clearance or Hold Order is not At the Job Site.

The holder of a Clearance or Hold Order shall only hold one Clearance or Hold Order at a time for active work because they can only be At the Job Site for one Clearance or Hold Order at a time. Additional Clearances and Hold Orders may be issued to the same individual for proximity work or for induced voltage reduction.

The holder of a Clearance or Hold Order may perform defined incidental work activities and still be considered At the Job Site, but those activities must be temporary in nature and of a short duration (i.e. 15 minutes or less).

Incidental work for one Clearance or Hold Order cannot be incidental work for a second Clearance or Hold Order.

See the Glossary definitions of active work, incidental work, and proximity work.

For Clearances or Hold Orders inside substations, at no point may the incidental work activities require the holder of the Clearance or Hold Order to leave the physical confines of the substation

For Clearances or Hold Orders on transmission lines, at no point may the incidental work activities require the holder of the Clearance or Hold Order to leave the workers unless they are travelling to another group of workers under the same

Clearance or Hold Order, provided radio or cell phone contact can be maintained with the Dispatcher and all groups of workers.

For electrical testing under a Work Clearance, the Clearance Holder shall supervise or perform the electrical testing by physically being present at the location where the electrical testing is being performed. There shall only be one electrical test at a time since the Clearance Holder can only be in one location at a time.

For electrical testing under a Test Clearance, the Clearance Holder shall supervise or perform the electrical testing and may supervise or perform electrical testing at more than one location simultaneously. This is allowed with a Test Clearance because there can only be one Clearance Holder as opposed to a Work Clearance which has the potential for multiple Clearance Holders on the same lines or equipment.

Any questions regarding application of this interpretation should be directed to the Substation Operations Group (TOZ)

GLOSSARY OF SPECIAL TERMS AND PHRASES

Active Work: Any work that is performed on lines or equipment under the protection of a Clearance or Hold Order. Crews are only allowed to perform work on lines or equipment under the protection of a Clearance or Hold Order when the holder of the Clearance or Hold Order is At the Job Site.

Adjustable Rod Gap: A switching device on 500 kV line terminals. Reducing the rod gap spacing provides added protection for workers while performing live-line work.

Air Circuit Breaker (ACB): A low voltage mechanical switching device designed to open and close a circuit by non-automatic means under normal conditions, and to open the circuit automatically during an overload or short circuit condition.

Assurance of no Backfeed: The assurance given by a utility that at a specific point of interconnection they have no means of backfeeding that circuit, or if they have an alternative source of power, that source is isolated from the interconnection and the isolation point will not be closed without the permission from the BPA Dispatcher.

At the Job Site: At the location where the work is being performed. The holder of a Clearance or Hold Order may place or respond to telephone or radio calls, perform paperwork incidental to the job at hand, use available restroom facilities, or perform other minor tasks incidental to the work and still be considered "At the Job Site".

For Clearances and Hold Orders issued for work on transmission lines where the work requires workers at more than one location, the holder of the Clearance or Hold Order is considered to be "At the Job Site" when with a group of workers or traveling between groups of workers, provided that radio or cell phone contact can be maintained with the Dispatcher and all groups of workers.

Authorized Employee: A person who locks out or tags out machines or equipment to perform the servicing or maintenance on that machine or equipment.

Bonding: The interconnection of conductive parts designed to maintain a common electrical potential.

Clearance (Work or Test): Assurance given to a worker by a System Dispatcher or Substation Operator that:

1. Specified power system equipment, or a transmission line is isolated from the power system, and;
2. It will not be ordered energized from the power system until that worker reports the crew in the clear and the equipment or line ready for service and the Clearance is released.

Competent Person: One who is capable of identifying existing and predictable hazards in the surroundings, or working conditions which are unsanitary, hazardous, or dangerous to employees, and who has authorization to take prompt corrective measures to eliminate them.

Control Point: Equipment controls that automatically or can be remotely closed to energize a high voltage circuit. Isolating devices are not considered control points.

Electrical Worker: Contract journeyman, electrical apprentice, journeyman in training, temporary electrical worker.

Electrically Safe Work Condition: A state in which an electrical conductor or circuit part has been protected by the use of dielectric barriers to prevent contact by persons or conductive objects OR has been disconnected from energized parts, locked/ tagged in accordance with established standards, tested to ensure the absence of voltage and grounded/bonded if determined necessary.

Employee: As applied in Chapter One: Is any BPA employee represented by the Columbia Power Trades Council. As applied in Chapter Two: Is any BPA employee not represented by the Columbia Power Trades Council.

Energy Source: Any source of electrical, mechanical, hydraulic, pneumatic, chemical, thermal or other energy.

Energy Source Control: The use of a device or procedure that ensures any potentially hazardous stored or residual energy be relieved, disconnected, restrained and otherwise rendered safe.

Equipotential Zone (EPZ): A work zone in which the worker is protected from electrical shock differences in potential between conductive objects in the work area. These differences in potential can be caused by induced voltage, line reenergization or lightning.

Group Display Board: The large one-line diagram board of the power system installed in control centers.

Hold Order: Assurance given to a worker by a System Dispatcher or Substation Operator that if specified power system equipment or a transmission line is de-energized, it will not be ordered energized until that worker reports the crew in the clear.

Human Machine Interface (HMI): A computer screen that allows a qualified employee to interact with a device or system. At BPA substations with sequential events recorders (SER), the HMI displays time-stamped SER alarms. At BPA substations with combined supervisory control and data acquisition (SCADA) and SER systems, the HMI displays SER alarms and allows for suppression or blocking of SER and SCADA alarms. At BPA substations with a control HMI, the HMI allows the qualified employee to control and provide indication of the high voltage power system equipment and tagging.

Incidental Work: Specific and defined work activities of a temporary nature and short duration (i.e. 15 minutes or less) that the holder of a Clearance or Hold Order is allowed to perform and still be considered At the Job Site.

Job-related incidental work activities are strictly defined as only paperwork and minor tasks necessary to complete work on lines or equipment under the protection of a Clearance or Hold Order.

Non-job-related incidental work activities are strictly defined as only using restroom facilities and answering or placing phone or radio calls.

Isolating Device: Electrical apparatus used to isolate power system lines and equipment from a source of energization. High voltage isolating devices include disconnect switches, hot-stick links, removable bus links, sectionalized jumper couplings or transmission line jumpers, which provide an air-gap of approved design for the circuit, or gas-insulated disconnect switches which are contained within an SF6 gas reservoir operating at or above normal gas density. Low voltage isolating devices are used to isolate high voltage equipment from potential backfeed through a source of low voltage energization. These devices include ACBs, disconnect switches, removable fuses, or other positive isolating means*. Low voltage isolating devices do not include automatic transfer switches and non-lockable manual transfer switches.

*BPA Work Standard BPA-WS-8-1, Lockout/Tagout defines other positive isolating means for example: removing valve handles, lifting, taping leads from the load side of the breaker, removing plug-in type breakers from the panel, etc.

Isolating Device, Rendered Inoperable: Using manufacturer-designed or BPA-approved, alternate means of preventing inadvertent closing by a natural event, and locked to prevent inadvertent operation. All high voltage isolating devices tagged with a Do Not Operate tag shall be rendered inoperable if design permits. If a device cannot be rendered inoperable,

because its design does not permit, tag it to indicate employees are at work. Some examples of isolating devices that cannot be rendered inoperable: Low voltage ACBs used as Clearance limits, hot-stick operated disconnects, fused disconnects, and certain jumpers or similar circuit parts.

Limits of a Clearance: Boundaries of a Clearance designated by high voltage isolating devices which are open, rendered inoperable (if its design permits), and properly tagged with a red Do Not Operate tag. All high voltage isolating devices tagged with a Do Not Operate tag shall be rendered inoperable if design permits.

Log: A permanent record maintained at each substation and control center.

Nominal Voltage: The value assigned to a system or circuit of a given voltage class for the purpose of convenient designation. The actual voltage may vary above or below this value.

Normally Energized: High voltage power system equipment is considered "normally energized" if it is energized or could be energized by closing an isolating device.

Power Circuit Breaker (PCB): A high voltage mechanical switching device capable of making, carrying, and breaking currents under normal circuit conditions and also making, carrying, and breaking for a specified time, currents under specified abnormal conditions such as a short circuit.

Power System Equipment: All mechanical, electrical, or electronic equipment or circuits required for the operation of a high voltage power system.

Proximity Work: Work being performed near normally energized high voltage facilities where inadvertent movement of personnel or equipment could result in violating the applicable Minimum Approach Distance.

Qualified Electrical Worker (QEW): A person knowledgeable in the construction and operation of electric power generation, transmission, and distribution equipment involved, along with the associated hazards. To be considered a QEW, a person must have completed an approved apprenticeship or training program with demonstrated experience and competency in their respective craft as determined by management, and the training required by DOL/OSHA 1910.269 (a)(2)(ii). Only a QEW with an Electrical Worker Permit (EWP) is authorized to wear a yellow hard hat.

Qualified Employee/Qualified Person: Any person trained and familiar with the work practices, procedures, and safety requirements that pertain to their job assignment and deemed qualified by their employer to perform the task.

Sectionalizing Jumper Coupling (SJC or “Neushwanger”): A BPA designed hot stick operated device used to primarily (but not exclusively) connect a high voltage transmission line jumper to a line sectionalizing disconnect switch; they can be operated while energized under specified conditions as a means to isolate short sections of transmission line or equipment.

Shorting (Short Circuiting): The process that establishes a metallic connection between two or more points in an electrical circuit that has the capacity to conduct any anticipated current.

Switchman: Any person who, by experience or training is familiar with the operation to be performed and the hazards involved and is, in the judgement of the dispatcher, qualified to perform the assigned switching.

Switching Order: A step-by-step plan to perform switching operations in a specific sequence.

Terminal Clearance: A formal assurance of isolation of a Local Terminal or Terminals* of an interconnecting circuit provided by the Local System Dispatcher** to a requesting Dispatcher. The Terminal Clearance assures the requesting Dispatcher that

the terminal or source is open, properly cleared and tagged according to local procedures, and that it will not be energized until a release is given by the Dispatcher receiving the Terminal Clearance.

*A Local Terminal is a terminal of an interconnecting circuit under the authority of the Local System Dispatcher.

**The Local System Dispatcher is the Dispatcher who has the authority over a Local Terminal or Terminals of an interconnecting circuit.

Terminal Hold: A formal assurance of non-reclosure at the Local Terminal or Terminals* of an interconnecting circuit provided by the Local System Dispatcher** to a requesting Dispatcher. The Terminal Hold assures the requesting Dispatcher that the terminal or source on “Hold” has sufficient relays in service to provide protection in the event of a fault; and, once tripped out of service, will not be energized, automatically or manually until the Dispatcher receiving the Terminal Hold has advised that all personnel and materials are in the clear and it is safe to energize.

Test Voltages: Electrical voltages and currents applied to power system facilities with testing equipment for the purpose of calibration, information or testing. Power system voltages are not considered “test voltages”.

Underground Residential Distribution (URD): Refers to electrical equipment that incorporates metal enclosures, barriers, and insulated cables and connectors typically used to serve residential and light industrial loads. At BPA, URD equipment is used to provide station service electric power in substations and to non-electric plant (NEP) facilities. Typical operating voltages for URD equipment range from 120/240 VAC to 34.5k VAC. URD equipment may also be referred to as “Pad-Mount” or “Metal Enclosed” which are also industry accepted terms.

URD Grounds: Grounds that may be used for protection against electric shock in conjunction with the grounding of URD equipment or cables. URD grounds are fitted with standardized insulated connectors (elbows) on one end and are designed to connect to the insulated bushings of metal enclosed URD transformers or switches. URD grounds have limited fault current carrying capacity due to limitations in the insulated elbow connectors and not necessarily the cable itself. URD grounds are limited to 10,000 amps (12t) for 10 cycles, 5,800 amps for 30 cycles, and 3,500 amps for 3 seconds.

Work Permit: Permission granted to work on power system equipment when the work does not require a Clearance or Hold Order, including equipment that has been de-energized for induced voltage reduction. A Work Permit does not provide electrical contact protection for personnel or permit the violation of applicable Minimum Approach Distances.